











WALL: BIANCO VEIN CUT 80x160 - NUANCES GIADA 120x260x0,6
FLOOR: BIANCO VEIN CUT 80x160

Dorset

GRES PORCELLANATO - RETTIFICATO / PORCELAIN STONEWARE - RECTIFIED

FEINSTEINZEUG - KALIBRIERT / GRES CERAME - RECTIFIÉ / GRES PORCELANICO

CONFORMING TO STANDARDS
EN 14411 ISO 13006 APPENDICE G GRUPPO BIa UGL CON Ev ≤ 0,5%

 BENDING STRENGTH	 FROST RESISTANCE	 CHEMICALS RESISTANCE	 STAIN RESISTANCE
 ANSI A326.3 > 0,42	 R10 / A+B	 ANSI A326.3 > 0,42	
REALUP / STRIDEUP	REALUP / STRIDEUP	NATURALE / MATTE	
 ANSI A326.3 > 0,42	 R11 / A+B+C		
ANTISLIP OPEN	ANTISLIP OPEN		

HEAVY TRAFFIC
TRAFFICO INTENSO

Naturale / Matte
RealUp / StrideUp
Antislip
OPEN

V2
MODERATE

All Colours

ADVANCED TECHNOLOGY

RealUp
StrideUp











DOWNLOAD CATALOGUE

7 FORMATI RETTIFICATI / RECTIFIED SIZES FORMATE KALIBRIERT / FORMATS RECTIFIÉS

	6 mm - MEGA		9 mm - RealUp + StrideUp						20 mm - OPEN	
SUPERFICIE SURFACE	120x280x0,6 cm 47 1/4"x110 1/4"x1/4"	80x160 cm 31 1/2"x63"	120x120 cm 47 1/4"x47 1/4"	60x120 cm 23 1/2"x47 1/4"	80x80 cm 31 1/2"x31 1/2"	60x60 cm 23 1/2"x23 1/2"	30x60 cm 11 7/8"x23 1/2"	Not rectified 30x60 cm 11 7/8"x23 1/2"	60x120 cm 23 1/2"x47 1/4"	60x60 cm 23 1/2"x23 1/2"
Naturale / Matte	■									
RealUp + StrideUp		■	■	■	■	■	■			
Ribbed				■						
Antislip				■				■	■	■

8 COLORI / COLOURS FARBEN / COULEURS

							
BIANCO CROSS CUT	BIANCO VEIN CUT	BEIGE CROSS CUT	BEIGE VEIN CUT	TORTORA CROSS CUT	TORTORA VEIN CUT	CENERE CROSS CUT	CENERE VEIN CUT

4 SUPERFICI / SURFACE FINISHES OBERFLÄCHEN / SURFACES

			
NATURALE / MATTE	REALUP / STRIDEUP	RIBBED	ANTISLIP



WALL: BIANCO 120x280x0,6 - BIANCO RIBBED 60x120
WASHBASIN: LOOM PIANO 180 NUANCES MURETTO GIADA 30x30
FLOOR: BIANCO 120x120



WALL: TORTORA 120x280x0,6 - LUCE 120x280x0,6
FLOOR: TORTORA 120x120



WALL: CENERE 120x280x0,6 - NUANCES GIADA 120x280x0,6
COUNTER: NUANCES LISTELLO TRATTO GIADA 20x120x0,6
FLOOR: CENERE 120x120

BIANCO CROSS CUT



BIANCO VEIN CUT



BIANCO CROSS CUT RIBBED



Il Decoro Ribbed non ha continuità di struttura tra un pezzo e l'altro.
Le décor Ribbed n'a pas de continuité entre une pièce et l'autre.
Ribbed decor has no continuity of texture between the pieces.
Bei dem Dekor Ribbed gibt es keine Kontinuität der Linienstruktur zwischen einem Stück und dem nächsten.

BEIGE CROSS CUT



BEIGE VEIN CUT



BEIGE CROSS CUT RIBBED



Il Decoro Ribbed non ha continuità di struttura tra un pezzo e l'altro.
Le décor Ribbed n'a pas de continuité entre une pièce et l'autre.
Ribbed decor has no continuity of texture between the pieces.
Bei dem Dekor Ribbed gibt es keine Kontinuität der Linienstruktur zwischen einem Stück und dem nächsten.

	6 mm - MEGA	9 mm - RealUp + StrideUp						20 mm - OPEN	
SUPERFICIE SURFACE	120x280x0,6 cm 47 1/4"x110 1/4"x1/4"	80x160 cm 31 1/2"x63"	120x120 cm 47 1/4"x47 1/4"	60x120 cm 23 1/2"x47 1/4"	80x80 cm 23 1/2"x23 1/2"	60x60 cm 23 1/2"x23 1/2"	30x60 cm 11 7/8"x23 1/2"	30x60 cm 11 7/8"x23 1/2"	60x120 cm 23 1/2"x47 1/4"
Naturale / Matte Natur / Naturel	UGL BIANCO CROSS CUT DR01XPA ■								
RealUp / StrideUp			DR0112 ■	DR01BA ■	DR0188 ■	DR0168 ■	DR0163 ■		
Ribbed				DR02GA ■	DR02BA ■		DR0263 ■		
Antislip				DR01BAR ■				DR0160A ■	DR01BA2 ■

	6 mm - MEGA	9 mm - RealUp + StrideUp						20 mm - OPEN		
SUPERFICIE SURFACE	120x280x0,6 cm 47 1/4"x110 1/4"x1/4"	80x160 cm 31 1/2"x63"	120x120 cm 47 1/4"x47 1/4"	60x120 cm 23 1/2"x47 1/4"	80x80 cm 23 1/2"x23 1/2"	60x60 cm 23 1/2"x23 1/2"	30x60 cm 11 7/8"x23 1/2"	30x60 cm 11 7/8"x23 1/2"	60x120 cm 23 1/2"x47 1/4"	60x60 cm 23 1/2"x23 1/2"
Naturale / Matte Natur / Naturel	UGL BEIGE CROSS CUT DR03XPA ■									
RealUp / StrideUp			DR0312 ■	DR03BA ■	DR0388 ■	DR0368 ■	DR0363 ■			
Ribbed				DR04GA ■	DR04BA ■		DR0463 ■			
Antislip				DR03BAR ■				DR0360A ■	DR03BA2 ■	DR03682 ■

TORTORA CROSS CUT



TORTORA VEIN CUT



TORTORA CROSS CUT RIBBED

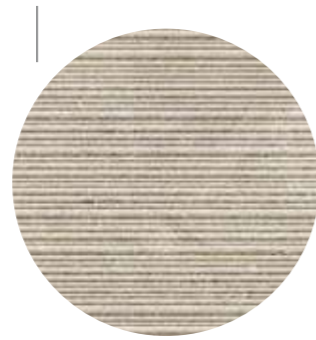

Il Decoro Ribbed non ha continuità di struttura tra un pezzo e l'altro.
Le décor Ribbed n'a pas de continuité entre une pièce et l'autre.
Ribbed decor has no continuity of texture between the pieces.
Bei dem Dekor Ribbed gibt es keine Kontinuität der Linienstruktur zwischen einem Stück und dem nächsten.

CENERE CROSS CUT



CENERE VEIN CUT



CENERE CROSS CUT RIBBED

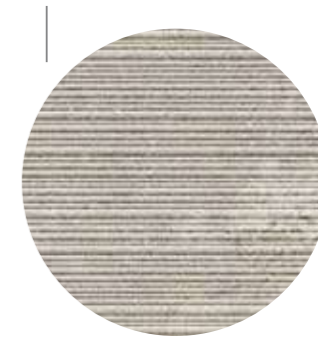

Il Decoro Ribbed non ha continuità di struttura tra un pezzo e l'altro.
Le décor Ribbed n'a pas de continuité entre une pièce et l'autre.
Ribbed decor has no continuity of texture between the pieces.
Bei dem Dekor Ribbed gibt es keine Kontinuität der Linienstruktur zwischen einem Stück und dem nächsten.

	6 mm - MEGA	9 mm - RealUp + StrideUp						Not rectified
SUPERFICIE SURFACE	120x280x0,6 cm 47 ^{1/4} "x110 ^{1/4} "x1/4"	80x160 cm 31 ^{1/2} "x63"	120x120 cm 47 ^{1/4} "x47 ^{1/4} "	60x120 cm 23 ^{1/2} "x47 ^{1/4} "	80x80 cm 23 ^{1/2} "x23 ^{1/2} "	60x60 cm 23 ^{1/2} "x23 ^{1/2} "	30x60 cm 11 ^{7/8} "x23 ^{1/2} "	30x60 cm 11 ^{7/8} "x23 ^{1/2} "
Naturale / Matte Natur / Naturel	UGL TORTORA CROSS CUT DR05XPA ■							
RealUp / StrideUp			DR0512 ■	DR05BA ■	DR0588 ■	DR0568 ■	DR0563 ■	
Ribbed				DR05BAR ■				
Antislip				DR05BAA ■				DR0560A ■

	6 mm - MEGA	9 mm - RealUp + StrideUp						20 mm - OPEN		
SUPERFICIE SURFACE	120x280x0,6 cm 47 ^{1/4} "x110 ^{1/4} "x1/4"	80x160 cm 31 ^{1/2} "x63"	120x120 cm 47 ^{1/4} "x47 ^{1/4} "	60x120 cm 23 ^{1/2} "x47 ^{1/4} "	80x80 cm 23 ^{1/2} "x23 ^{1/2} "	60x60 cm 23 ^{1/2} "x23 ^{1/2} "	30x60 cm 11 ^{7/8} "x23 ^{1/2} "	Not rectified 30x60 cm 11 ^{7/8} "x23 ^{1/2} "	60x120 cm 23 ^{1/2} "x47 ^{1/4} "	60x60 cm 23 ^{1/2} "x23 ^{1/2} "
Naturale / Matte Natur / Naturel	UGL CENERE CROSS CUT DR07XPA ■									
RealUp / StrideUp				DR0712 ■	DR07BA ■	DR0788 ■	DR0768 ■	DR0763 ■		
Ribbed					DR07BAR ■					
Antislip					DR07BAA ■			DR0760A ■	DR07BA2 ■	DR07682 ■

LISTELLO TRATTO CROSS CUT

20x120



Bianco Cross Cut 6 mm
Beige Cross Cut 6 mm
Tortora Cross Cut 6 mm
Cenere Cross Cut 6 mm

MURETTO CROSS CUT

30x30



Bianco Cross Cut 6 mm / 9 mm
Beige Cross Cut 6 mm / 9 mm
Tortora Cross Cut 6 mm / 9 mm
Cenere Cross Cut 6 mm / 9 mm

MURETTO VEIN CUT

30x30



Bianco Vein Cut 9 mm
Beige Vein Cut 9 mm
Tortora Vein Cut 9 mm
Cenere Vein Cut 9 mm

MOSAICO CROSS CUT

30x30



Bianco Cross Cut 9 mm
Beige Cross Cut 9 mm
Tortora Cross Cut 9 mm
Cenere Cross Cut 9 mm

MOSAICO VEIN CUT





30x30



Bianco Vein Cut 9 mm
Beige Vein Cut 9 mm
Tortora Vein Cut 9 mm
Cenere Vein Cut 9 mm

6 mm - MEGA Naturale / Matte - UGL

9 mm - RealUp + StrideUp - UGL

	 Listello Tratto 20x120 cm 8x47 ^{1/4} "	 Muretto 30x30 cm 11 ^{7/8} "x11 ^{7/8} "	 Muretto 30x30 cm 11 ^{7/8} "x11 ^{7/8} "	 Mosaico 30x30 cm 11 ^{7/8} "x11 ^{7/8} "
	Pcs Box 6	Pcs Box 6	Pcs Box 6	Pcs Box 12
BIANCO CROSS CUT	DR01LT	DR01MB	DR01MB9	DR013MA
BIANCO VEIN CUT			DR02MB9	DR023MA
BEIGE CROSS CUT	DR03LT	DR03MB	DR03MB9	DR033MA
BEIGE VEIN CUT			DR04MB9	DR043MA
TORTORA CROSS CUT	DR05LT	DR05MB	DR05MB9	DR053MA
TORTORA VEIN CUT			DR06MB9	DR063MA
CENERE CROSS CUT	DR07LT	DR07MB	DR07MB9	DR073MA
CENERE VEIN CUT			DR08MB9	DR083MA



Su rete / Mesh mounted



Tessera
2,5x120 1"x47^{1/4}"

Listello Tratto



Tessera
2,8x9,8 1^{1/8}"x3^{7/8}"

Muretto



Tessera
5x5 2"x2"

Mosaico

DECORO RILIEVO 3D

Design Andrea Parisio & Giuseppe Pezzano



Bianco Vein Cut
20x120 - 20x120 inciso sul retro
40x120 - 40x120 inciso sul retro

+

Bianco Vein Cut
60x120



Beige Vein Cut
20x120 - 20x120 inciso sul retro
40x120 - 40x120 inciso sul retro

+

Beige Vein Cut
60x120



Tortora Vein Cut
20x120 - 20x120 inciso sul retro
40x120 - 40x120 inciso sul retro

+

Tortora Vein Cut
60x120



Cenere Vein Cut
20x120 - 20x120 inciso sul retro
40x120 - 40x120 inciso sul retro

+

Cenere Vein Cut
60x120

9 mm - RealUp + StrideUp



Decoro Rilievo 3D
120x120
(20x120 2pz - 40x120 2pz)
(8"x47 1/4" 2pcs - 15 3/4"x47 1/4" 2pcs)

SUPERFICIE
SURFACE

Pcs Box 4

RealUp +
StrideUp UGL

BIANCO VEIN CUT	DR02DRL
BEIGE VEIN CUT	DR04DRL
TORTORA VEIN CUT	DR06DRL
CENERE VEIN CUT	DR08DRL

Le scatole dei listelli sono così composte / The listels boxes are composed as follows

Jeder Karton besteht aus den folgenden Produkten / Les boites des listels sont composées par :

- 1 pezzo 20x120
- 1 pezzo 20x120 inciso sul retro / engraved on the back / auf der Rückseite eingepägt / gravé au dos
- 1 pezzo 40x120
- 1 pezzo 40x120 inciso sul retro / engraved on the back / auf der Rückseite eingepägt / gravé au dos

SCHEMI DI POSA A 3 FORMATI / INSTALLATION SYSTEMS WITH 3 SIZES

Per garantire un progetto di posa a regola d'arte, consigliamo uno schema random alternando - ai formati 20x120 e 40x120 - il fondo 60x120 cm.

To ensure a proper installation, we recommend a random pattern by alternating the 20x120cm (8"x48") and 40x120cm (32"x48") sizes with the 60x120cm (24"x48") field tile.

Um ein fachgerechtes Verlegebild zu gewährleisten, empfehlen wir ein zufälliges Schema, bei dem sich die Formate 20x120 und 40x120 mit den 60x120 Grundfliesen abwechseln.

Pour assurer un projet réalisé dans la règle de l'art, nous préconisons un schéma aléatoire en alternant aux formats 20x120 et 40x120 l'uni en 60x120.

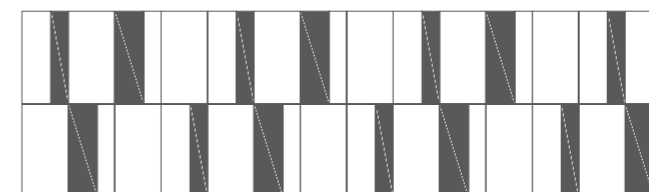

SIZES	20x120 20x120 inciso sul retro / engraved on the back 40x120 40x120 inciso sul retro / engraved on the back	60x120
% MQ	50%	50%

Nello schema accanto i formati incisi sul retro sono indicati dal colore grigio.
In the pattern beside, the sizes engraved on the back are indicated by the color grey.
In der nebenstehenden Abbildung sind die auf der Rückseite eingepägten Formate durch die Farbe Grau gekennzeichnet.
Dans le tableau ici à côté, les formats gravés sur le dos sont indiqués en gris.

DECORO RILIEVO 3D Design Andrea Parisio & Giuseppe Pezzano

Nell'immaginare questo decoro gli architetti Andrea Parisio e Giuseppe Pezzano si sono ispirati alla plasticità dei rivestimenti lapidei che caratterizzano l'architettura dei palazzi italiani. Rilievo 3D è un decoro che abbina un listello posato in modo planare ad un listello il cui lato maggiore viene posato in sovrapposizione, creando un modulo dall'originale effetto di tridimensionalità. Ciò è possibile grazie all'incisione effettuata sul retro, che in fase di installazione genera l'effetto 3D.

In imagining this decoration, the architects Andrea Parisio and Giuseppe Pezzano were inspired by the plasticity of the wall stone that characterize the architecture of Italian buildings. The

decoration combines a listel laid flatly with a listel which longer side is installed overlapping. This creates a module with an original three-dimensional effect. The overlapping is possible thanks to the engraving made on the back of the strip, which generates the 3D effect.

Bei der Realisierung dieses Dekors ließen sich die Architekten Andrea Parisio und Giuseppe Pezzano von der Plastizität der für italienische Gebäude typischen Natursteinverkleidungen inspirieren. Die Dekoration kombiniert einen planar verlegten Riemen mit einem weiteren Riemen, dessen längere Seite überlappend verlegt wird. So entsteht ein Modul mit einer originellen dreidimensionalen Optik. Die

Überlappung ist dank der Gravur auf der Rückseite des Riemens möglich, die bei der Verlegung die 3D-Optik erzeugt.

En imaginant cette décoration, les architectes Andrea Parisio et Giuseppe Pezzano se sont inspirés de la plasticité des revêtements en pierre caractéristiques de l'architecture des palais italiens. La décoration associe un listel posé à plat à un listel dont le grand côté est posé en superposition afin de créer un module offrant un effet tridimensionnel original. La superposition est possible grâce à l'incision effectuée à l'arrière du listel qui, lors de l'installation, génère l'effet 3D.

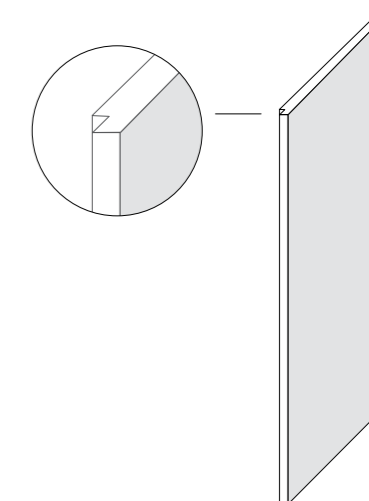

9 mm

	Battiscopa	Gradone con Toro	Elemento "L" Incollato
	7x60 cm 2 ^{3/4} "x23 ^{1/2} "	120x33x4 cm 47 ^{1/4} "x13 ^{3/4} "	4,5x16,5x60 cm 1 ^{3/4} "x6 ^{1/2} "x23 ^{1/2} "
	Pcs Box 10	Pcs Box 2	Pcs Box 4
SUPERFICIE SURFACE			
BIANCO CROSS CUT	RealUp + StrideUp	DR0176 ■	DR01GT2 ■
BIANCO VEIN CUT	RealUp + StrideUp	DR0276 ■	DR02GT2 ■
BIANCO CROSS CUT	Antislip		DR0195I ■
BEIGE CROSS CUT	RealUp + StrideUp	DR0376 ■	DR03GT2 ■
BEIGE VEIN CUT	RealUp + StrideUp	DR0476 ■	DR04GT2 ■
BEIGE CROSS CUT	Antislip		DR0395I ■
TORTORA CROSS CUT	RealUp + StrideUp	DR0576 ■	DR05GT2 ■
TORTORA VEIN CUT	RealUp + StrideUp	DR0676 ■	DR06GT2 ■
TORTORA CROSS CUT	Antislip		DR0595I ■
CENERE CROSS CUT	RealUp + StrideUp	DR0776 ■	DR07GT2 ■
CENERE VEIN CUT	RealUp + StrideUp	DR0876 ■	DR08GT2 ■
CENERE CROSS CUT	Antislip		DR0795I ■



SPECIAL PIECES
■ 20 mm OPEN

Per approfondimenti sui pezzi speciali e tutti gli accessori per esterno 20mm scarica la scheda tecnica oppure consultare il nostro sito e il catalogo Open.

For further information on special pieces and all 20mm outdoor accessories download the technical data sheet or consult our website and the Open catalog.

Für weitere Informationen zu Sonderteilen und dem gesamten 20-mm-Outdoor-Zubehör laden Sie das technische Datenblatt herunter oder besuchen Sie unsere Website und den Open-Katalog.

Pour approfondissements sur les pièces de finition et accessoires pour extérieurs en 20mm, merci de télécharger la fiche technique ou bien consulter notre site web et le catalogue OPEN.



WALL: NUANCES MOSAICO GIADA 30x30
FLOOR: BEIGE 60x120 20MM - NUANCES MOSAICO GIADA 30x30
CANALINA 8x14x60 20MM - CANALINA ANGOLARE 8x14x60 20MM GRIGLIA 14x60 20MM

					PCS / BOX	M ² / BOX	KG / BOX	BOX / PALLET	M ² / PALLET	KG / PALLET				
	80x160 cm - 31 ^{1/2} "x62 ^{7/8} "	Thick 9 mm	RealUp + StrideUp	PZ / PCS	2	M ²	2,56 KG	51,84	PZ / PCS	18	M ²	46,08	KG	953,17
	120x120 cm - 47 ^{1/4} "x47 ^{1/4} "	Thick 9 mm	RealUp + StrideUp	PZ / PCS	2	M ²	2,88 KG	58,70	PZ / PCS	18	M ²	51,84	KG	1.076,76
	60x120 cm - 23 ^{1/2} "x47 ^{1/4} "	Thick 9 mm	RealUp + StrideUp Ribbed	PZ / PCS	2	M ²	1,44 KG	28,95	PZ / PCS	36	M ²	51,84	KG	1.062,23
	60x120 cm - 23 ^{1/2} "x47 ^{1/4} "	Thick 9 mm	Antislip	PZ / PCS	2	M ²	1,44 KG	28,76	PZ / PCS	36	M ²	51,84	KG	1.055,46
	OPEN 60x120 cm - 23 ^{1/2} "x47 ^{1/4} "	Thick 20 mm	Antislip	PZ / PCS	1	M ²	0,72 KG	32,03	PZ / PCS	36	M ²	25,92	KG	1.173,22
	80x80 cm - 31 ^{1/2} "x31 ^{1/2} "	Thick 9 mm	RealUp + StrideUp	PZ / PCS	2	M ²	1,28 KG	24,96	PZ / PCS	40	M ²	51,20	KG	1.018,40
	60x60 cm - 23 ^{1/2} "x23 ^{1/2} "	Thick 9 mm	RealUp + StrideUp	PZ / PCS	4	M ²	1,44 KG	28,26	PZ / PCS	30	M ²	43,20	KG	868,58
	OPEN 60x60 cm - 23 ^{1/2} "x23 ^{1/2} "	Thick 20 mm	Antislip	PZ / PCS	2	M ²	0,72 KG	31,85	PZ / PCS	30	M ²	21,60	KG	975,56
	30x60 cm - 11 ^{7/8} "x23 ^{1/2} "	Thick 9 mm	Antislip	PZ / PCS	8	M ²	1,44 KG	28,20	PZ / PCS	32	M ²	46,08	KG	922,40
	Not Rectified 30x60 cm - 11 ^{7/8} "x23 ^{1/2} "	Thick 9 mm	Antislip	PZ / PCS	8	M ²	1,44 KG	28,20	PZ / PCS	32	M ²	46,08	KG	859,61
	Listello Tratto 20x120 cm - 8"x47 ^{1/4} "	Thick 6 mm	RealUp + StrideUp	PZ / PCS	6	M ²	1,44 KG	19,30	PZ / PCS	30	M ²	43,20	KG	599,06
	Listello 3D 20x120 cm - 8"x47 ^{1/4} " 40x120 cm - 16"x47 ^{1/4} "	Thick 9 mm	RealUp + StrideUp	PZ / PCS	4	M ²	1,44 KG	30,00	PZ / PCS	-	M ²	-	KG	-
	Muretto 30x30 cm - 11 ^{7/8} "x11 ^{7/8} "	Thick 9 mm	RealUp + StrideUp	PZ / PCS	6	M ²	0,54 KG	10,02	PZ / PCS	60	M ²	32,40	KG	632,00
	Muretto 30x30 cm - 11 ^{7/8} "x11 ^{7/8} "	Thick 6 mm	RealUp + StrideUp	PZ / PCS	6	M ²	0,54 KG	7,81	PZ / PCS	60	M ²	32,04	KG	489,08
	Mosaico/ Mosaico Vein Cut 30x30 cm - 11 ^{7/8} "x11 ^{7/8} "	Thick 9 mm	RealUp + StrideUp	PZ / PCS	12	M ²	1,08 KG	20,62	PZ / PCS	30	M ²	32,40	KG	638,60

IMBALLI MEGA	DESCRIZIONE IMBALLO PACKAGING DESCRIPTION	MQ / KG LASTRA / SLAB	IMBALLO PIENO FULL PACKAGING	IMBALLO VUOTO EMPTY PACKAGING
	CASSA / CRATE L 145 x P 292 x H 35	MQ 3,36	MQ 67,20	
		KG 48,60	KG 1062,00	KG 100,00
	CAVALLETTI / A-FRAME L 75 x P 285 x H 153	MQ 3,36	MQ 147,84	
		KG 48,60	KG 2318,40	KG 180,00
	CASSA LIGHT / LIGHT CRATE L 145 x P 292 x H 27	MQ 3,36	MQ 30,24	
		KG 48,60	KG 527,40	KG 90,00
			PZ 1 / 9	

STUCCHI CONSIGLIATI / RECOMMENDED GROUTS

Colori Colors	Bianco Cross Cut / Bianco Vein Cut	Beige Cross Cut / Beige Vein Cut	Tortora Cross Cut / Tortora Vein Cut	Cenere Cross Cut / Cenere Vein Cut
Kerakoll	05	44	44	08
Mapei	111	123	187	112

Pag. 367: approfondimenti calibri specifici / Pag. 367: further information on specific working sizes / S. 367: Vertiefungen über spezifische Werkmaße / Pag. 367 : approfondissements dimensions de fabrication spécifiques